

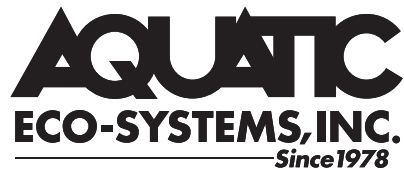

***Oilless Rotary Vane Compressor  
Operating and Maintenance Instructions  
(Part Nos. AQ3 - AQ93)***



Part No. \_\_\_\_\_ Serial Number \_\_\_\_\_ Date Purchased \_\_\_\_\_



# Table of Contents

	Page
<b>Message from the President</b> .....	2
<b>Safety Messages</b> .....	2
<b>Guidelines for Product Use</b> .....	2
<b>Operation Guidelines</b> .....	2
Installation .....	2
Plumbing .....	3
Starting .....	3
<b>General Maintenance</b> .....	3
Flushing the Muffler System .....	3
Vane Replacement .....	3
<b>Frequently Asked Questions (FAQ)</b> .....	4
<b>Troubleshooting Chart</b> .....	4
<b>Exploded View of Compressors</b> .....	5
<b>Standard Warranty</b> .....	5

Dear Customer,  
 Thank you for your purchase of Sweetwater® equipment. We believe that the Sweetwater® name represents the finest blend of quality, performance and price on the market. Our Sweetwater® products are thoroughly tested so that we can give you reliable, accurate information about real-world operation.

We value your business and look forward to meeting all your needs with the world's largest selection of aquatic tools. Aquatic Eco-Systems has delivered outstanding products and service since 1978. We have the knowledge and experience to help you accomplish your goals.

Best regards,



Robert C. Heideman  
 Founder and President

AES is open from 8 a.m. to 7 p.m. Monday-Thursday,  
 8 a.m. to 5 p.m. Friday and 10 a.m. to 2 p.m. Saturday.  
 For technical help call 407-886-3939.

## Safety Messages

Safety is important to us. We have included safety messages throughout this manual and for your protection. Please read and follow all directions.

A safety message has a safety alert symbol followed by an explanation of what the hazard is, what can happen and what you should do to avoid injury. This is the safety alert symbol:



The safety alert symbol and "WARNING" or "CAUTION" will precede all safety messages:



### WARNING

**You will be killed or seriously injured if you don't follow instructions.**



### CAUTION

**You can be killed or seriously injured if you don't follow instructions.**

- Do not pump flammable or explosive gases or use in an atmosphere that contains such gases.
- Protect all surrounding items from exhaust air. This exhaust air can become very hot.
- Corrosive gases and particulate material will damage the unit. Water vapor, oil-based contaminants or other liquids must be filtered out.
- Do not flush with kerosene or other combustible solvents.



### ELECTRICAL SHOCK HAZARD

Disconnect electrical power at the circuit breaker or fuse box before installing this product. Install where it will not come into contact with water or other liquids and where it will be weather protected. Electrically ground this product. Failure to follow these instructions can result in death, fire or electrical shock.

## Guidelines for Product Use

- Pump only clean, dry air.
- Operate at 32-104°F (0-40°C).
- Protect unit from dirt, foreign material and moisture.
- Never lubricate oilless air compressors.
- Use of petroleum or hydrocarbon products will reduce carbon vane life.

## Operation Guidelines

### Installation

Make sure the wiring is done by a qualified electrician familiar with NEMA MG2 safety standards, national electric code and all local safety codes. Select fuses, motor protective switches or thermal protective switches to provide protection. Fuses act as short circuit protection for the motor, not as protection against overload. Incoming line fuses help to withstand the motor's starting current. Motor starters with thermal magnetic overload or circuit breakers protect the motor from overload or reduced voltage conditions. The wiring diagram attached to the product provides required electrical information.

Check that power source is correct to properly operate the dual-voltage motor. All dual-voltage motors are shipped from the factory wired for 115V unless otherwise requested.

Make sure that installation clearances do not block air flow. Blocking air flow over the product in any way can cause the product to overheat.



## WARNING

**Product surfaces become very hot during operation; allow them to cool before handling.**

The air stream from this product may contain solid or liquid material that can cause eye or skin damage; wear proper eye protection. Failure to follow these instructions can result in burns, eye injury or other serious injury.

Each model has an automatic thermal protector that shuts the motor off if it overheats. The motor will restart without warning once the protector resets itself upon cooling.

This product can be installed in any orientation. To minimize noise and vibration, the unit should be mounted on a solid surface that will not resonate. We recommend the use of shock mounts or vibration isolation material. Inlet noise can be minimized by attaching an optional muffler.

### Plumbing

Remove plugs from the IN and OUT ports. Connect with pipe and fittings that are the same size or larger than the product's threaded ports.

### Starting

If the compressor is extremely cold, allow it to warm to room temperature before starting. If the motor fails to start or slows down when under load, shut it off and unplug it. Check that the supply voltage agrees with the motor post terminals and motor data name plate, and make sure the motor is turning in the proper direction. Vane life will be drastically reduced if the motor is not operating properly. Vanes can break or be damaged if the motor runs in the wrong direction.

## General Maintenance



## WARNING

**When servicing, all power to the motor must be discharged and the plug disconnected. All rotating components must be at a standstill.**

Make sure that pressure and vacuum are released from the product before starting maintenance. Check intake and exhaust filters after the first 500 hours of operation. Clean filters, and determine how frequently filters should be checked during future operation. This procedure in particular will help the product's performance and service life.

1. Remove the end plate and filters. Inspect filters for rips, tears, cuts, brittleness and excessive foreign material.
2. Clean filters if in good condition with compressed air. Reinspect for wear conditions. Set filters aside.

3. Check the filter/muffler for compacted debris. If debris is present, replace the filter/muffler.
4. Check the condition of O-ring. It should be soft and flexible. Replace if it is not.
5. Remove and inspect the muffler box (not all models have a muffler box). Clean the box and set it aside.
6. Check the gasket for cracks or tears. Install new gasket if any cracks or tears exist.
7. Replace the muffler box.
8. Reinstall filters or install new filters if required. Reinstall the end plate.

### Flushing the Muffler Assembly

Should excessive dirt, foreign particles, moisture or oil be permitted to enter the compressor, the vanes will act sluggish or even break. Flushing the muffler assembly should remove these materials. Do not use kerosene or other combustible solvents. Use flushing solvent (AES part no. **AQ255**) liberally to clean muffler parts.

### Vane Replacement

Aquatic Eco-Systems recommends carbon vane replacement at nine-month intervals to ensure trouble-free operation of your compressor. The following tools are required:  $\frac{3}{8}$ " or  $\frac{7}{16}$ " socket/wrench, small hammer and antiseize compound.

1. Remove the two end caps from the front of the muffler box (if applicable) and the five muffler box bolts, being careful not to damage the gasket. If the gasket is torn, scrape it off with a sharp knife and replace.
2. Tap the box with a small hammer to loosen it. Do not pry with a screwdriver.
3. Remove the six bolts holding the end plate to the body. Remove the end plate. Do not remove the rotor or loosen any of the electric motor through bolts.
4. Check that vanes are moving freely in and out of vane slots. Replace any vane if more than 50% extends past the vane slot. Top clearance (between rotor and body) may be adjusted by loosening body bolts and lightly tapping on the compressor body while turning the rotor. About .004 inch—this paper's thickness—works well.
5. Remove vanes and clean both sides with fine emery cloth. Clean the end plate with fine emery cloth.
6. Flush vanes, body, rotor and end plate with solvent (AES part no. **AQ255**), and remove all solvent from each part.

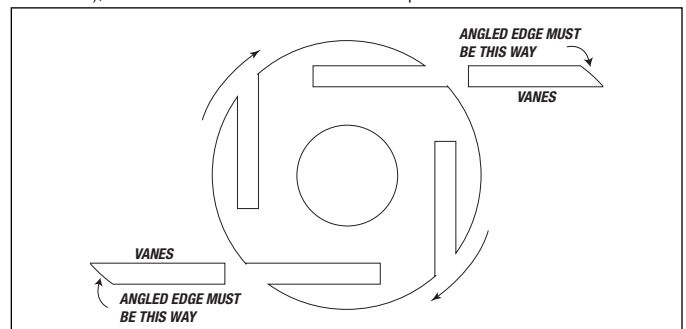

7. Check the body, rotor and end plate for scoring. If each part is clean and shows no signs of scoring, reinstall parts. If scoring is present, replace with new part(s) or contact Aquatic Eco-Systems for service.
8. Insert new vanes as shown below.

Top clearance (between rotor and body) may be adjusted by loosening body bolts and lightly tapping on the compressor body while turning the rotor. About .004 inch—this paper's thickness—works well.

Reassemble by reversing the previous directions. AES always recommends using an antiseize lubricant on each bolt to ensure its easy removal for the next vane replacement. Bolts should be reinstalled and tightened in a similar manner to replacing the lug nuts on a vehicle wheel. Start with one bolt and move to the right, skipping one and tightening the next.

When reinstalling the muffler box (if applicable), be certain to install the center bolt first to ensure proper gasket alignment. Before replacing the muffler box, plug your compressor in for a quick sound check of the valve rotation. If an unusual sound or stopping of the rotor takes place, disconnect and recheck the vane replacement.

### Frequently Asked Questions (FAQ)

#### Is my compressor running too hot?

It is normal for a motor to run hot to the touch because the shell transfers heat away from the motor windings.

However, improved materials used in motor manufacturing make the "too-hot-to-touch" test obsolete. The best way to determine if a motor is operating properly is to check the ampere (amp) draw. Each motor has a nameplate listing full-load amps (FLA). If the tested amp draw does not exceed the nameplate rating, its internal or external cooling fan is working (if so equipped), and the ambient air temperature around the motor is below 104°F (40°C). The motor is probably not running hot, even though it is too hot to touch.

Even so, make sure that there is plenty of air flow around the motor, and keep the area around the motor clear so that there is no blockage of air flow to the motor. Also keep paint and other flammable materials away from the motor.

#### How much will it cost to operate my compressor?

The cost of operation will depend on the length of time the compressor is run each day. The following example is for a typical 1-hp, single-phase compressor operated 24 hours a day at \$.08 per kWh. The cost per kWh will vary from location to location. Check your electric bill for the cost per kWh.

$$9.7 \text{ amps} \times 115 \text{ volts} = 1,115.5 \text{ watts (amps \& volts are on motor nameplate)}$$

$$1,115.5 \text{ watts} \times 1,000 = 1.116 \text{ kW}$$

$$1.116 \text{ kW} \times 24 \text{ hrs} = 26.77 \text{ kWh}$$

$$26.77 \text{ kWh} \times \$.08 \text{ per kWh} = \$2.14 \text{ per day}$$

#### Why is my compressor so noisy?

Compressor noise can be the result of vibration or mechanical noise.

1. Vibration is the intensification of normal compressor noise. The noise should decrease if the compressor is firmly attached to the foundation or if the compressor is completely isolated by using a rubberized or cushioned base.

2. Mechanical noise is typically a high-pitched squealing sound. The most common causes include worn motor bearings and rubbing of the impeller against the compressor housing.

#### What causes my compressor to turn off by itself?

Check to make sure the proper voltage is supplied to the compressor. Most compressors are dual voltage, meaning that they are capable of using either 115V or 230V. The motor may have been wired for 230V. If you are using 115V, you will need to change the wiring (see wire diagram on the motor nameplate). Contact a licensed electrician if you need help with wiring modifications.

A high-temperature switch will turn the motor off if it overheats. The switch will automatically reset itself and turn on after the motor cools. If this overheating and restarting cycle continues for a period of time, the temperature switch will ultimately fail. This cycle will also shorten the life of the motor.

High amp draw results in overheating. High amperage is caused by the following:

1. Low voltage. Usually caused by power supply wire being undersized and/or wire being too long. Extension cords are not recommended to power larger compressors. If you believe that this may be the problem, contact a licensed electrician to check your installation.
2. Motor is locked up. Something may be lodged in the impeller, causing parts to bind.
3. Worn motor bearings.

The compressor may be set up with an automatic timer that will control the run time so that you don't have to manually turn the compressor on and off.

### Troubleshooting Chart

Low Pressure	High Pressure	Compressor Overheat	Motor Overload	Problem Cause and Solution
X		X	X	Filter dirty. Clean or replace.
X	At Compressor	X	X	Plugged or collapsed pressure line. Inspect and repair.
X				Vanes sticking. Clean or replace.
X				Vanes worn. Replace.
X				Shaft seal worn. Replace.
X		X	X	Debris in compressor. Inspect and clean.
X		X	X	Motor not wired correctly. Check wiring diagram and line voltage.

Should you require service or repair parts, contact Aquatic Eco-Systems at 407-886-3939 from 8 a.m. to 7 p.m. Monday to Thursday, 8 a.m. to 5 p.m. Friday and 10 a.m. to 2 p.m. Saturday. Have your part and serial numbers handy, and our technical staff will gladly help you resolve any problems.

## Exploded View of Compressor

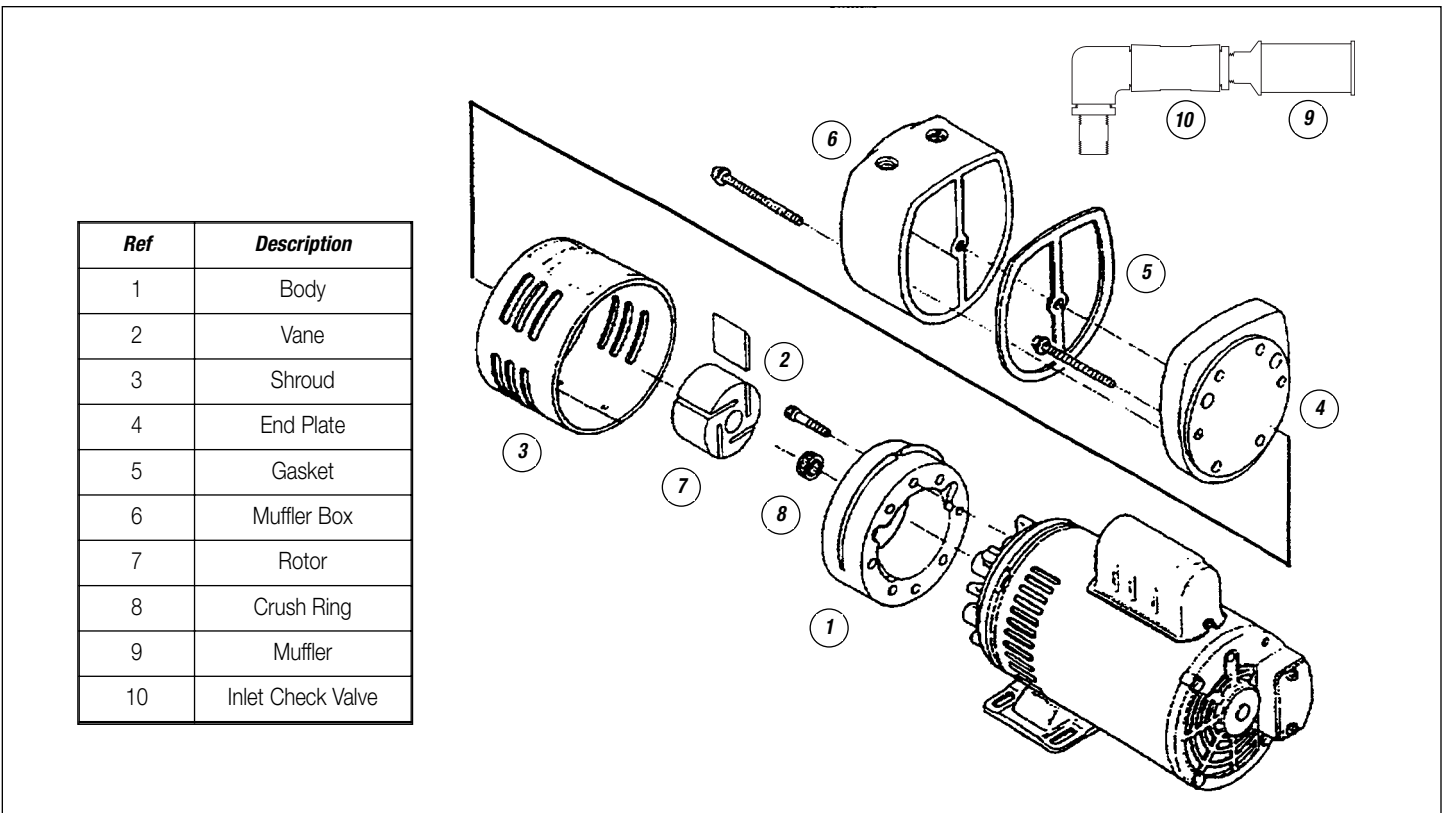

### Standard Warranty

Aquatic Eco-Systems, Inc. (AES) products, when properly installed and operated under normal conditions of use, are warranted by AES to be free from defects in material and workmanship for a period of 12 months from the date of invoice from AES, unless otherwise stated. In order to obtain performance under this warranty, the buyer must promptly give verbal or written notice of the defect by calling the AES Returns Department at 407-886-3939, sending a fax to 407-886-6787 or by e-mail to [aes@aquaticeco.com](mailto:aes@aquaticeco.com). The buyer is responsible for freight charges, both to and from AES, in all cases.

AES warranties do not extend to any goods or parts which have been subjected to misuse, modification, lack of maintenance, neglect, transit damage or damage resulting from lightning, natural or accidental flooding, fire or accident. Operating use or circumstances outside normal conditions, such as high heat or high moisture, may also be excluded from this warranty.

THIS EXPRESS WARRANTY EXCLUDES ALL OTHER WARRANTIES OR REPRESENTATIONS EXPRESSED OR IMPLIED BY ANY LITERATURE, DATA OR PERSON. THE MAXIMUM LIABILITY OF AES UNDER THIS EXCLUSIVE REMEDY SHALL NEVER EXCEED THE COST OF THE SUBJECT PRODUCT AND AES RESERVES THE RIGHT, AT ITS SOLE DISCRETION, TO REFUND THE PURCHASE PRICE IN LIEU OF REPAIR OR REPLACEMENT.

AES WILL NOT BE RESPONSIBLE OR LIABLE FOR INDIRECT OR CONSEQUENTIAL DAMAGES OF ANY KIND, however arising, including but not limited to those for use of any products, loss of time, inconvenience, lost profit, labor charges or other incidental or consequential damages with

respect to persons, animals, business or property, whether as a result of breach of warranty, negligence or otherwise. Notwithstanding any other provision of this warranty, BUYER'S REMEDY AGAINST AES FOR GOODS SUPPLIED OR FOR NONDELIVERED GOODS OR FAILURE TO FURNISH GOODS, WHETHER OR NOT BASED ON NEGLIGENCE, STRICT LIABILITY OR BREACH OF EXPRESS OR IMPLIED WARRANTY IS LIMITED SOLELY, AT THE OPTION OF AES, TO REPLACEMENT OF OR CURE OF SUCH NONCONFORMING OR NONDELIVERED GOODS OR RETURN OF THE PURCHASE PRICE FOR SUCH GOODS AND, IN NO EVENT, SHALL EXCEED THE PRICE OR CHARGE FOR SUCH GOODS. AES EXPRESSLY DISCLAIMS ANY WARRANTY OF MERCHANTABILITY OR FITNESS FOR A PARTICULAR USE OR PURPOSE WITH RESPECT TO THE GOODS SOLD. THERE ARE NO WARRANTIES WHICH EXTEND BEYOND THE DESCRIPTIONS SET FORTH IN THIS WARRANTY, notwithstanding any knowledge of AES regarding the use or uses intended to be made of goods, proposed changes or additions to goods or any assistance or suggestions that may have been made by AES personnel.

Unauthorized extensions of warranties by the customer shall remain the customer's responsibility.

CUSTOMER IS RESPONSIBLE FOR DETERMINING THE SUITABILITY OF AES PRODUCTS FOR CUSTOMER'S USE OR RESALE OR FOR INCORPORATING THEM INTO OBJECTS OR APPLICATIONS THAT THE CUSTOMER DESIGNS, ASSEMBLES, CONSTRUCTS OR MANUFACTURES.

This warranty can be modified only by AES personnel by signing a specific, written description of any modifications.

**AQUATIC**  
**ECO-SYSTEMS, INC.**  
 Since 1978